

# Installation & Handling Guide: Seamless Fascia Post

CureWood Engineered Building Products  
Surrey, BC  
Feb 2026

The performance and durability of wood products and coatings installed in an exterior environment is directly dependent upon the material's ability to shed water and dry. Proper installation must prevent prolonged exposure to moisture. Failure to follow storage and installation instructions will void this product's warranty.

## STORAGE AND TRANSPORT

All CureWood Seamless Fascia Posts will arrive in a wrapped, bundled, pack of lumber. Lumber wrap is a breathable non-permeable wrap designed to keep product dry and protected from the elements before installation. Every full pack of CureWood Seamless Fascia Posts are shipped from our production facility with a sheet of bottom protection and banding corner protectors to ensure no damage is done during transport from our facility to customer locations.

- Whenever possible, the CureWood Seamless Fascia Post should be stored in an enclosed building.
- CureWood Seamless Fascia Post must be kept free from any source of moisture in delivery, storage, material handling, and installation.
- Always store Curewood Seamless Fascia Posts flat, fully supported and elevated from the ground, but resting on a non abrasive support (powder coated steel, clean wood dunnage or blocking, ect).
- If stored outside, a waterproof covering installed in a manner to shed water should be used. Keep the cover open at the bottom to permit air circulation, and ensure it is fastened properly to not shift in changing weather conditions or relocation.
- Seamless Fascia Posts are not to be stacked higher than three packs high. Excessive weight will damage the combed finish and leave imprints where pressure was applied.

## INSTALLATION AND FASTENING

Adhere to the following to ensure the performance and durability of CureWood Seamless Fascia Post:

### GENERAL NOTES

- Always ensure compliance with the structural requirements for the project (structural drawings, Building Code etc.). Suitability and approval of CureWood Seamless Fascia Post for the project is NOT the responsibility of the Manufacturer.
- Follow all applicable local building codes.
- If cutting or alterations are required that break the factory applied primer, an acrylic-latex primer must be applied to re-seal the material and prevent moisture absorption. Place the altered and re-sealed end on the top and place the factory sealed end on the bottom.

## DRAINAGE & WATER MANAGEMENT

- CureWood Seamless Fascia Post must be installed with the following clearances between product and surrounding building components/surfaces:
  - 1/2" Clearance from underlying surfaces that may collect water (Examples: concrete, patios, decks)
  - 6" Clearance from unfinished grade
- The thickness of patio/deck surfaces installed after structural components must be accounted for in the design and installation in order to ensure that all clearance requirements are adhered to.

## FASTENERS & CONNECTORS

- Always pre-drill holes whenever possible
- Maximum hole size (diameter) drilled in CureWood Seamless Fascia Post is 1" (25mm)
- All holes drilled must be held back 2" (51mm) from edge of CureWood Seamless Fascia Post
- All holes drilled must be held back 1" (25mm) from end of CureWood Seamless Fascia Post
- Minimum distance between holes drilled in CureWood Seamless Fascia Post is 2" (51mm)
- In certain cases, notching of Seamless Posts is required and is permitted
- If trimming ends, must be square and flush and re-sealed with primer

For detailed information on fasteners & connections for your specific project/application always consult your project structural engineer. It is the responsibility of the building architect/designer, engineer, builder and installer to ensure that all Building Codes and requirements of the building authority for the area are being followed. This is NOT the responsibility of the product Manufacturer, Distributor or Dealer. Below are three typical use cases of how the Seamless Fascia Post can be installed in certain projects under certain conditions and code requirements.

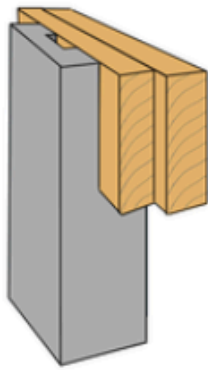

**Notched Beam Connection**  
Field-notched connection to beam

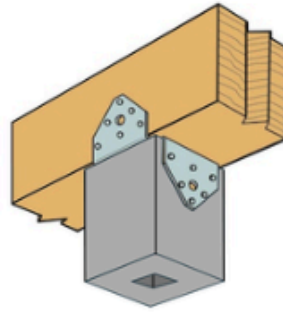

**Post Cap Connection**  
Surface-mounted post-to-beam hardware

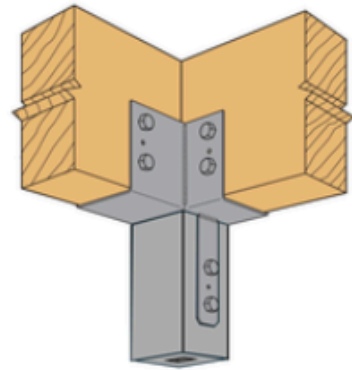

**Corner Post Cap Connection**  
Corner condition, multi-directional load transfer

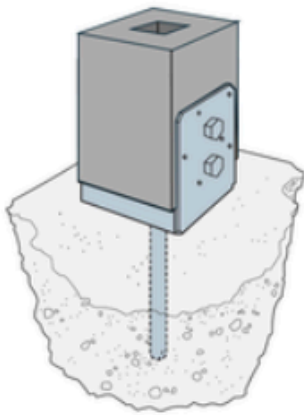

**Elevated Post Base**  
Raised post base for drainage clearance

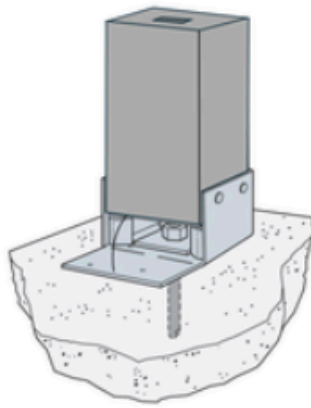

**Concealed Post Base (Uplift Rated)**  
Hidden hardware with uplift resistance

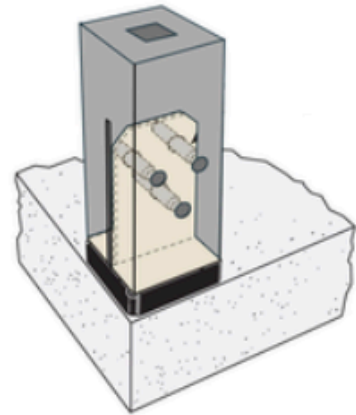

**Knife Plate Post Base**  
Embedded steel plate with concealed fasteners

## PAINTING AND FINISHING

- Curewood Seamless Fascia Post comes factory primed, but must have a top coat consisting of two coats of top quality acrylic-latex paint applied within 90 days of installation
- Paint must be applied to all surfaces of the Product.
- Always follow the coating manufacturer's application instructions. Ensure that all surfaces are free of dirt, dust, debris and moisture prior to coating installation.
- Always follow the coating manufacturer's maintenance instructions and inspect coatings regularly, on an annual basis at minimum, to ensure performance and durability.

Note: Home maintenance should be proactive, not reactive.